

ABS1339 Light Cable Clamps

Lightweight versions of ABS1339 legacy



Commercial Aerospace

Defence



ABS1339 Light series is the Lightweight version of the ABS1339 standard Cable Clamps series.

**WEIGHT SAVING
UP TO 18% !**

They are designed to keep the cable harnesses securely maintained on structure. They are fixed on structure by a screw and a washer (not supplied) and closed with a standard cable-tie (not supplied) of 5,5 mm width maximum.

Robust and flexible, ABS1339 Light clamps absorb shocks, vibrations, and offer an unequalled protection of bundles against pinching, crushing or mechanical wear, thanks to a silicone cushion.

RELIABILITY

They are suited for applications in standard environment (general use) and temperatures up to 150°C.

They are available in 8 sizes, for bundles diameters from 5 to 48 mm.

APPLICATIONS IN HARSH ENVIRONMENTS

Commercial Aerospace & Defence

STANDARDS AND QUALIFICATIONS

ABS1339 (products)
ABS1916 and ABS1337 (tests)

REACH AND ROHS

In accordance with the REACH spec.
In accordance with the RoHS spec.

CLAMP RANGE

8 sizes available

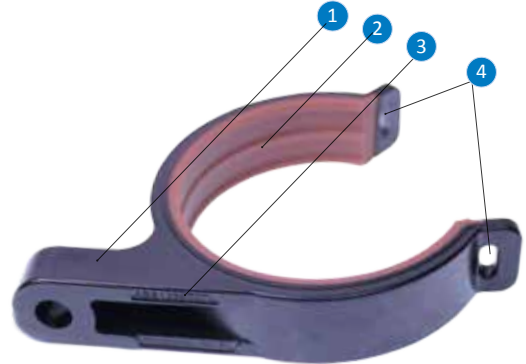

CAPTION

- 1 - Clamp Band
- 2 - Silicone Cushion
- 3 - ABS1339Light P/N engraved
- 4 - Fixing by cable-Tie 5,5 mm width max.

| Size | 01 | 02 | 03 | 04 | 05 | 06 | 07 | 08 |
|----------------------|--------|---------|------------|--------------|----------|------------|------------|------------|
| Bundle diameter (mm) | 5 to 8 | 8 to 11 | 10,5 to 14 | 13,5 to 19,5 | 19 to 26 | 25,5 to 33 | 32,5 to 40 | 39,5 to 48 |

MAIN TECHNICAL FEATURES

MATERIAL

Clamp Band : Thermoplastic
Cushion : Silicone elastomer

FLUIDS RESISTANCE : as per ABS1916 standard

Spray tests : Fuels, Hydraulic fluids, Lubrication Oils, Solvent and Cleaning fluids, De-icing fluids, insecticides

ENVIRONMENTAL

Operating Temperature : -55° to +150°C permanent

MECHANICAL : as per ABS1916 standard

Shocks : 6g during 20 ms
Vibrations : 3 H per axis, resonance frequency > 30 Hz
Windmilling test : 6g, frequency 2,9 to 30 Hz
Load test : depending on the clamp size, in 4 directions
Nose wheel imbalance : 3,5 to 10g, frequency 5 to 27 Hz

ELECTRICAL : as per ABS1916 standard

Insulation resistance : > 10⁶ MΩ

MOUNTING : as per ABS1916 standard

Closure and Fixing : Screw / washer Ø 5,2 mm
Screw / washer (recommended) : NSA1801-03 / NAS1149
Tightening torque : 3,2 Nm (+/- 0,5 Nm)
Clamp closure : Cable-tie (5,5 mm width)
Cable-tie (recommended) : NSA 935401-05

FLAMMABILITY / SMOKE / TOXICITY

ABD 0031
FAR 25.853

WEIGHTS

| Size | 01 | 02 | 03 | 04 | 05 | 06 | 07 | 08 |
|--|------|------|------|------|------|------|------|------|
| Weight of ABS1339 Light clamps (g) | 1,75 | 2,15 | 2,65 | 3,3 | 4,35 | 6,8 | 9,5 | 12,5 |
| Weight of ABS1339 standard clamps (g) | 2,1 | 2,5 | 3,2 | 4,0 | 5,3 | 8,3 | 11,5 | 14,6 |
| Weight saved versions Light / standard | -17% | -14% | -17% | -17% | -18% | -18% | -17% | -14% |

■ PART NUMBERING SYSTEM

ABS1339 D **01** L

Clamp size : 01 to 08

Lightweight version : L



■ TECHNICAL DRAWINGS

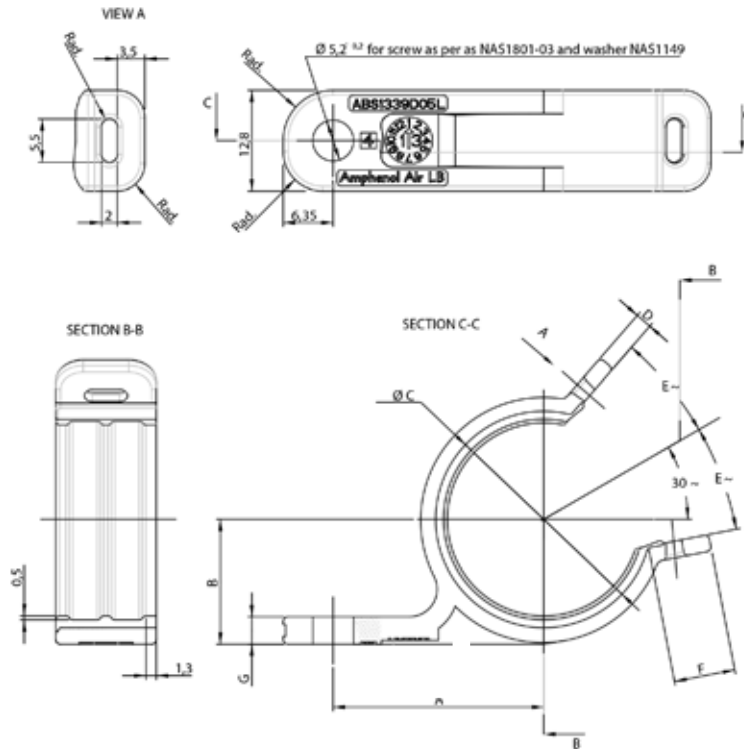

■ DIMENSIONS

| Part Number ABS | Clamp size | Admissible Bundle diameters (mm) | A (mm) | B (mm) | ØC (mm) | D (mm) | E (°) | F (mm) | G (mm) |
|--------------------|------------|-------------------------------------|-----------|-----------|------------|-----------|----------|-----------|-----------|
| ABS1339 D 01 L | 01 | 5 to 8 | 17 | 5,5 | 8 | 1,7 | 15 | 7,4 | 3,5 |
| ABS1339 D 02 L | 02 | 8 to 11 | 18,5 | 7,15 | 11 | 1,8 | 16 | 7,5 | |
| ABS1339 D 03 L | 03 | 10,5 to 14 | 20,4 | 9,2 | 14,8 | 1,9 | 17 | 7,6 | |
| ABS1339 D 04 L | 04 | 13,5 to 19,5 | 23,05 | 12 | 20,1 | 2 | 18 | 7,7 | |
| ABS1339 D 05 L | 05 | 19 to 26 | 26,75 | 15,85 | 27,5 | 2,1 | 19 | 7,8 | 5,8 |
| ABS1339 D 06 L | 06 | 25,5 to 33 | 31 | 20,25 | 36 | 2,5 | 20 | 7,9 | |
| ABS1339 D 07 L | 07 | 32,5 to 40 | 36 | 25,4 | 46 | 2,8 | 21 | 8 | 8,3 |
| ABS1339 D 08 L | 08 | 39,5 to 48 | 40 | 31 | 55 | | | | |

Fixing and closure of ABS1339 Light clamps are fulfilled in 2 steps.

Pre-mounting on structure is possible. Once clamps are mounted on structure and cable harnesses put in, then ABS1339 clamps can be closed.

■ CLAMPS FIXING

ABS1339 Light clamps are fixed on structure, using a screw and a washer (not supplied) matching the diameter of the fixing hole (5,2 mm). The ABS1339 standard recommend to use the following hardware :

- Screw : NSA1801-03
- Washer : NAS1149

Tightening torque : 3,2 Nm (nominal)



■ BUNDLE INSERTION & CLAMP CLOSING

Elastic properties of materials provide an easy insertion of Cable harnesses in the ABS1339 Light clamps.

They are closed with a cable-tie (5,5 mm width maximum). ABS1339 standard recommend to use a cable-tie as per NSA935401-05 standard. Use a cable-tie tool, as per MS 90387-1 (position 6 to 8), to provide the required tightening torque (about 120 N).

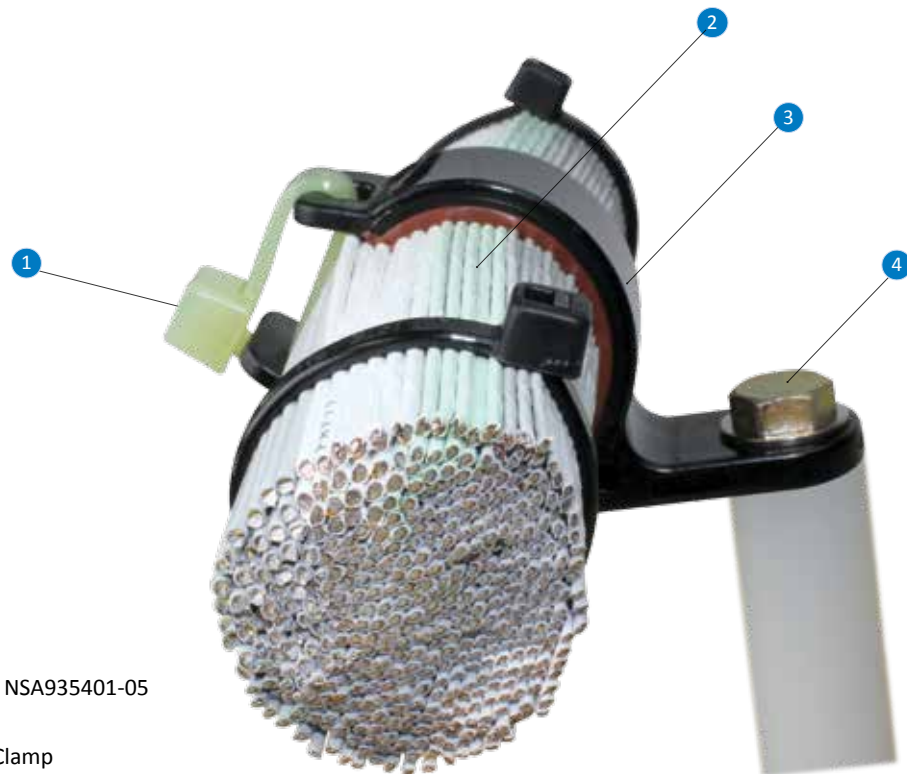

CAPTION

- ① - Cable-tie as per NSA935401-05
- ② - Bundle
- ③ - ABS1339 Light Clamp
- ④ - Screw NSA1801-03 + Washer NAS1149